

# ST60- Wireless

**cut the cable**



## Contents

<b>1 Introduction</b>	3
1.1 Operating modes	4
1.1.1 Standby mode	4
1.1.2 Operation mode	4
<b>2 Warning!</b>	5
<b>3 Technical data</b>	6
<b>4 Operating instruction</b>	7
4.1 LED display	7
4.2 LED's after PowerON	8
4.3 Button SW1 and corresponding displayed status	9
4.4 Learn-Mode	10
4.5 Configuration switches (in the receiver)	10
<b>5 Maintenance</b>	11
5.1 Maintenance	11
5.1.1 Battery change	11
5.1.2 Transmitter turn off => battery 'screw out'	11
<b>6 Installation</b>	12
6.1 Radio connection	12
6.2 Receiver	12
6.3 Transmitter	12
<b>7 Calibration</b>	13
7.1 ST60-Wireless	13
7.2 Raytheon calibration	13
7.3 ST60- transmitter and/or receiver exchange	13
<b>8 Function diagram</b>	14
<b>9 Troubleshooting</b>	15
<b>10 Dimensions</b>	16
10.1 Transmitter	16
10.2 Receiver	17
<b>11 Declaration of conformity</b>	18

## 1 Introduction

Thank you for your order of this ST60-Wireless set.  
We are convinced, that with the use of this device the installation will be much easier.  
The units are ruggediest and will serve you well for many years.

The ST60-Wireless replaces in a ST60 System the long cable from the windsensor to the ST60 Display through a radio transmission.

With this solution you don't need complicated wiring through the mast and the body of the boat. In addition you will have a reduction of weight up to 1 KG.

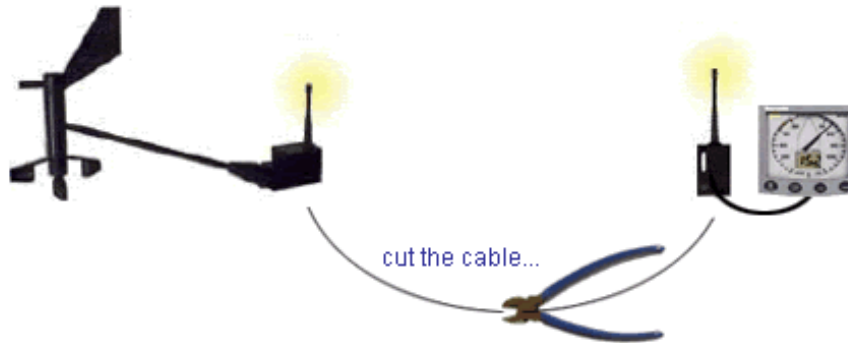

### ST60-Wireless device and its function



#### □ Transmitter

The original Wind Vane for measuring the direction and speed will be screwed directly on the transmitter. After mounting of the battery, the transmitter starts periodically measuring the sensor signals and sends this data by radio transmission to the receiver.



#### □ Receiver

The receiver converts this data to the original signals. The ST60 display 'sees' the same signals, as if they where transmitted by cable.

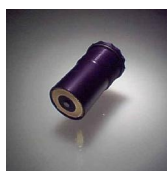

#### □ Battery, power management

For a simple handling and use in an extreme range of temperatur from  $-30^{\circ}\text{C}$  to  $+70^{\circ}\text{C}$  we use a high density energy Lithiumbattery. ( $-40^{\circ}\text{C}$ ... $+85^{\circ}\text{C}$  are possible without damaging the battery). Through a very efficient energy management, a battery can be used for many years. This type of battery can be stored for up to ten years, with a powerloss of only 1% per year.

!! this battery ist NOT reloadable and may NEVER be connected to a battery charger.

### 1.1 Operating modes

Different modes of operation

For economizing energy, the transmitter is used in different modes of operation. The main criterion is the power on time of the receiver.

#### 1.1.1 Standby mode

When the receiver is switched off, the transmitter terminates the heavy energy consuming measuring. It changes automatically in a standby mode with almost no use of current.

#### 1.1.2 Operation mode

As soon as the receiver is switched on, the transmitter notices the change and starts to measure and to transmit the data after a delay of 10..30 seconds. For low energy consumption the frequency to measure is automatically reduced every 12 hours.

## **2 Warning!**

For use of ST60-Wireless devices, the same information are valid as for the original ST60-System with cable.

**All ST60-Wireless equipment and accessories are designed to the best industry standards for use in the leisure marine environment.**

**Their design and manufacture conforms to the appropriate Electromagnetic Compatibility (EMC) standards, but correct installation is required to ensure that performance is not compromised.**

please visit our homepage:

**[www.seawave.ch](http://www.seawave.ch)**

for up to date information....

for your messages....

for your suggestions....

⋮  
⋮

### 3 Technical data

Radiofrequency	868.35MHz, band (see label on the device)	
Range	set-20 30m length of the mast, external antenne, ALU cover	
Battery	Lithium battery: 3.6V/7.2Ah with case. NOT reloadable	
Weight of transmitter	290g	without battery
Weight of receiver	105g	
Weight of battery	90g	
Temp.range operation	-30°C...+70°C	
Water resistance, long	on all outdoor wether condition	
Water resistance, short	transmitter under water (e.g mast is under water)	
Parallel operation	Several devices can work simultanious, without disturbing each other. Each device has its own identification code, that will be tuned during the 'learn mode'.	
Battery life standby	2...5 years	recevier OFF (bordnet switched off)
Battery life sailing	2...3 years	recevier ON (bordnet switched on)
Storage of battery	5...10 years	1% loss per year
Measuring cycles	<p>Wind direction: every 0.5...10 sec, depending of actual mode.          Wind speed : every 2...20 sec, dependig on actual mode and wind speed.          The measuring cycle (operating mode) in the transmitter is adaptable and is controlled by the receiver. It depends essentially from the switch on time of the receiver (boardnet on).          Every 12 hours the cycle time (operation mode) will be put back one step.          Operation modes are:  <b>racing =&gt; sailing =&gt; normal =&gt; slow.</b></p> <p>Operation starts in sailing mode after each switch on of the receiver (board net). Racing mode can be activated by pushing the SW1 button for 1 sec.</p>	

## 4 Operating instruction

ST60-Wireless is designed to work normally without any operation. At delivery the ST60 Wireless ist "ready to use"

Exeption: when a unit is exchanged, transmitter and receiver have to be synchronised in the "Learn mode" (see instruction below)

The receiver contains 7 LED's to sho

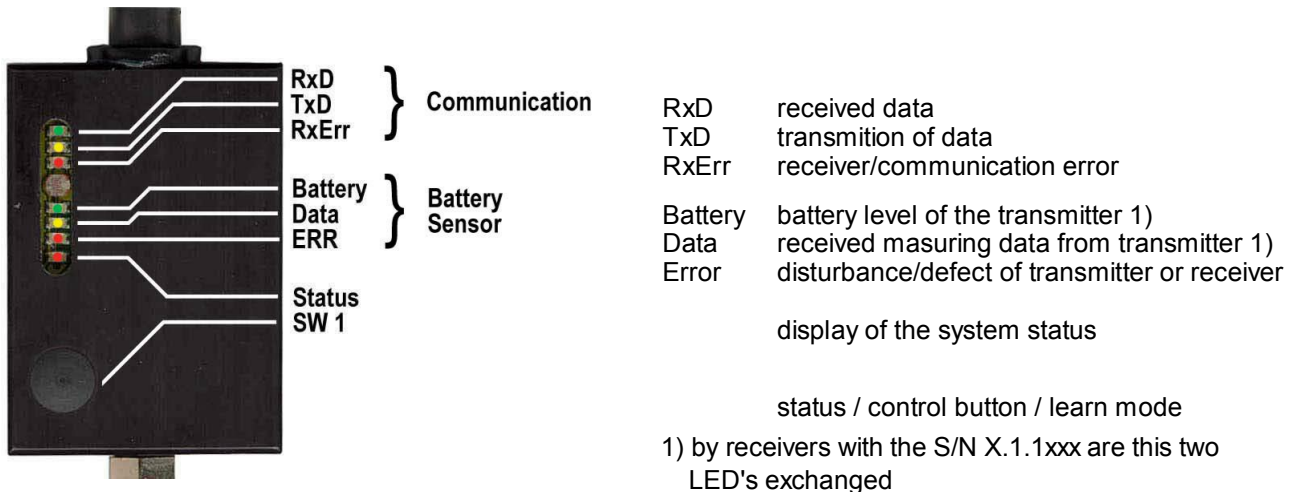

### 4.1 LED display

**RxD green** received data. Receives ST60-Wireless protocols

☐ short flash: received protocol, but not meant for this device

☐ long flash: received protocol, identified for this device

**TxD yellow** transmission of a ST60-Wireless protocol

☐ short flash for each outgoing protocol

**RxErr red** receiver- or communication error

☐ short flash: reception of any data or HF inputs

This LED shows reliably, if the "air is clean" from other HF-disturbing signals.

At intensiv flickering of this LED, the source of disturbance should be eliminated or the receiver should be better placed.

☐ long flash: reception of a corrupted protocol or protocol synchronisation error

## Battery green State of the transmitters battery voltage

The state of the battery is shown by this LED.

- permanent light => battery is full
- flashing light => battery reduced

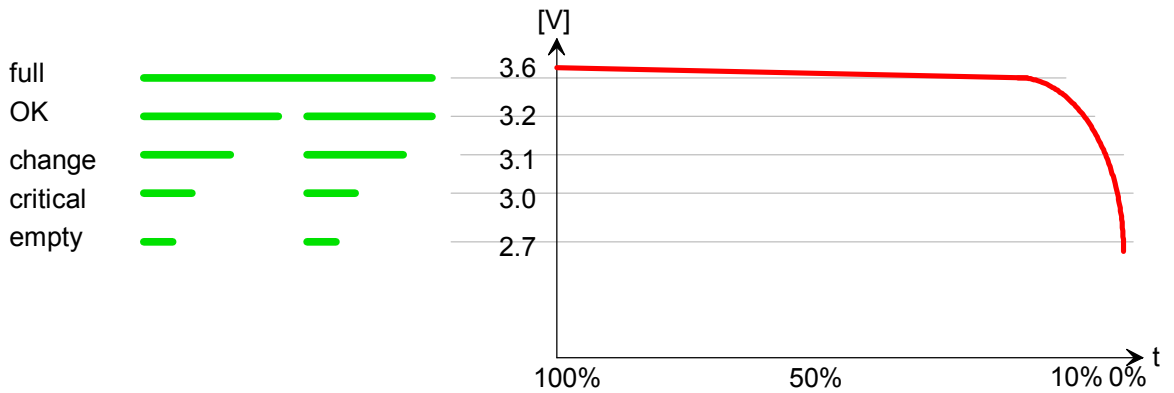

The important characteristic of the Lithium battery is, that the voltage is kept practically constant up to the end of life.

## Data gelb

- flash received measuring data from the transmitter or no data  
reception of valid sensor data: wind direction and -speed  
note: the transmitter will send data in uneven interval.  
This means that not regular blinking of LED is normal.
- permanent ON no communication for more than 10 seconds.  
The wind direction hand 'waves' between -30° and +30°

## ERR red

disturbance/defect of the transmitter or receiver

## STATUS red

display of the system status. see button SW1

## 4.2 LED's after PowerON

After Power ON you will see:

1. LED-Test all LED's ON
2. Configuration Position of the configurations switches

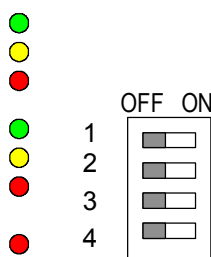

### 4.3 Button SW1 and corresponding displayed status

With the button SW1, parameters of the receiver can be called.

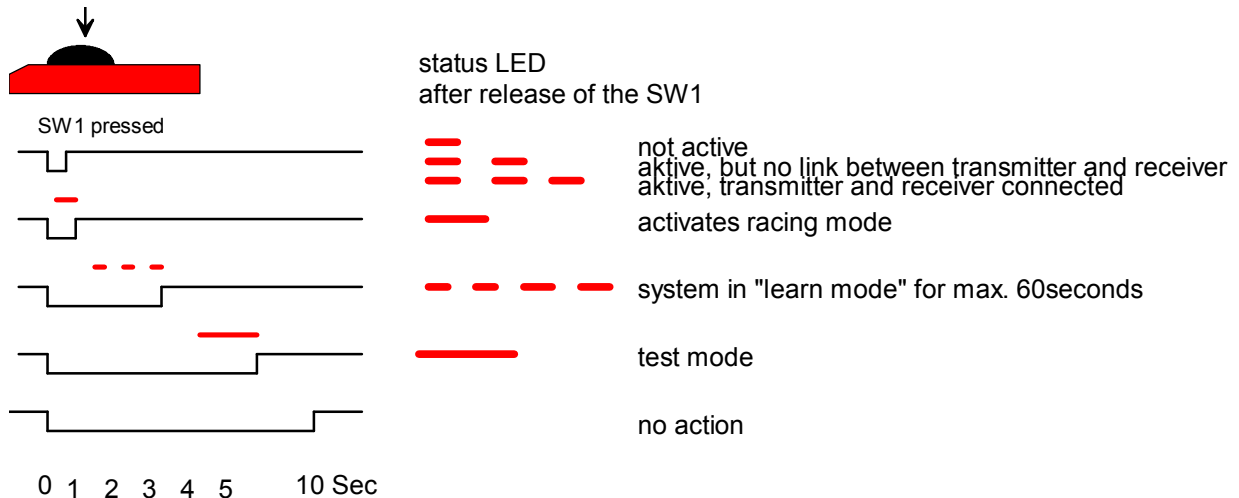

#### SW1 short push (0.2Sec)

Display of actual status of the receiver

- 1x flash receiver not active
- 2x flash receiver active, no link between receiver and transmitter
- 3x flash receiver active, receiver and transmitter connected

#### SW1 push (1Sec)

Activates racing mode. Transmitter measures and sends data every 0.5 seconds. Every 12 hours the cycle time (operation mode) will be put back one step. Operation modes: racing => sailing => normal => slow

#### SW1 push until LED1 starts to blink (5Sec)

Receiver changes to "learn mode" for 60 seconds.

If during this time a battery is screwed into the transmitter, this transmitter and the receiver being in the "learn mode" start synchronization.

After successful "learning" the LED goes on for 3 seconds. Transmitter and receiver will be restarted automatically.

The "learn mode" can be terminated any time by a short push on the button.

#### SW1 push until LED1 is permanently shining (10Sec)

The receiver changes into the "test mode" and shows on the display 0° and 0.0 KTS.

With each further push, the wind direction will be increased by 30° and the speed by 3 KTS.

The "test mode" can be terminated any time by a push on the button for 1 second.

If SW1 is not pushed for 3 minutes then the "test mode" will be automatically terminated.

Note: The displayed data in "test mode" are simulated and can vary from device to device.

They have no relation to the accuracy of the total system.

#### SW1 push until LED1 is no more shining (>10Sec)

no action.

## 4.4 Learn-Mode

Each ST60-Wireless equipment has world-wide a clear 32-Bit address. This address is used, so that only the matching devices can with one another exchange data. With the exchange of equipment transmitters and receivers must be co-ordinated again up in vein. This is made with a new ' learning '.

Proceed

1. Transmitter switch off => unscrews the battery min 10mm
2. set the receiver through pressures of SW1 (> 5Sec, until those flashes status LED) into the ' Learn mode ' sets.
3. Transmitter switch on => screw in the battery again.  
after a successful ' Learning ' the Status-LED light up for 3 seconds.  
Transmitters and receivers are again started.

Note:

The transmitter has no switch for the ' Learning '. In place of depressing the key the transmitter makes a test after each power on whether a receiver is in the ' Learn mode '. If it is so, an exchange of the addresses takes place with it.

Power ON

So that in the transmitter effective power on takes place, the battery must be screwed out and again in (to unscrew of approx. 10mm is enough)

If the transmitters makes not a measurement, it needs very little current, so that short removing of the battery is not enough, in order to switch the transmitter off effectively. Depending upon current mode this time can amount to 1...30 seconds. Wait thus with the screwing of the battery in sufficient long.

## 4.5 Configuration switches (in the receiver)

For special purposes the operating mode of the system can be affected with the configuration switch in the internal receiver.



n)	switch 1..4				function	energie used
	1	2	3	4		
1	OFF	OFF	x	x	Normal	normal
2	ON	OFF	x	x	slow measuring	medium
3	OFF	ON	x	x	very slow measuring	low
4	ON	ON	x	x	permanent on racing mode	high

not used switches always OFF

Examples

2) in the "Slow mode" with somewhat larger time intervals one measures.

approx. all 5..10Sec a measurement

3) in the "Slow mode" is only measured in large time intervals. approx. all 10..30Sec a measurement

4) the system always remains in the Racing mode. I.e. you have always the highest measuring rate. approx. all 0.5Sec a measurement.

## 5 Maintenance

### 5.1 Maintenance

The transmitters and receivers mechanical and electronic components are maintenance free.

#### 5.1.1 Battery change

From time to time the battery has to be exchanged.

It is not possible, to give a fixed maintenance interval, because the operation periode depends much about how the system is used. The power LED shows the state of the battery. The estimated operating time is 2..3 years.

We did our best, to make the battery change (evt. on the mast) as easy as possible.

The result is a battery pack, that can be screwed into the transmitter without a plug and will be installed without any tool.

□ screw out of the used battery

Should the battery be stucked, it can be loosened with the use of a **8mm 'Imbus'** key.

□ insert the new battery. Thats all!

It is sufficient to tighten the battery manually.

By using 8mm 'Imbus' key, please dont squeeze the O-Ring too much.

Note:

Please pay attention, to keep the contact surface of the battery always clean.

Please pay attention, to keep the O-Ring always clean.



Attention:

The battery is NOT reloadable. (Lithium dry battery)

NEVER connect the battery to a battery charger, and avoid shortcuts on the open contacts, for not to cause unnecessary energy loss.

Despite the very high energy density, shortcut is not dangerous, because the battery desposes of an internal power limitation.

#### 5.1.2 Transmitter turn off => battery 'screw out'

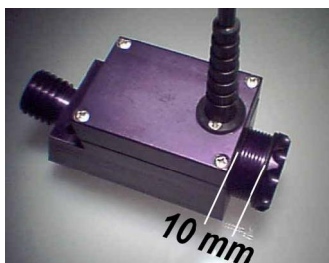

If you want to put off the transmitter fully, e.g during winter, screw out the battery for min. 10mm. Dont screw out the battery completely, you avoid with that the spring contact getting unnecessarily dusty.

## 6 Installation

Transmitter and receiver may be connected without further preparation.

Before you climb the mast, we recommend to test the devices on the ground, to be sure, that everything functions.

### 6.1 Radio connection

Transmitter and receiver exchange data over radio signals. Such a radio connection is without problem (also in closed cabin) if you watch the following guidelines:

- don't install the transmitter or receiver in a metal case
- don't install the transmitter or receiver too near to motors.... that could cause disturbance
- install the transmitter and receiver in a way to be "in view" of each other

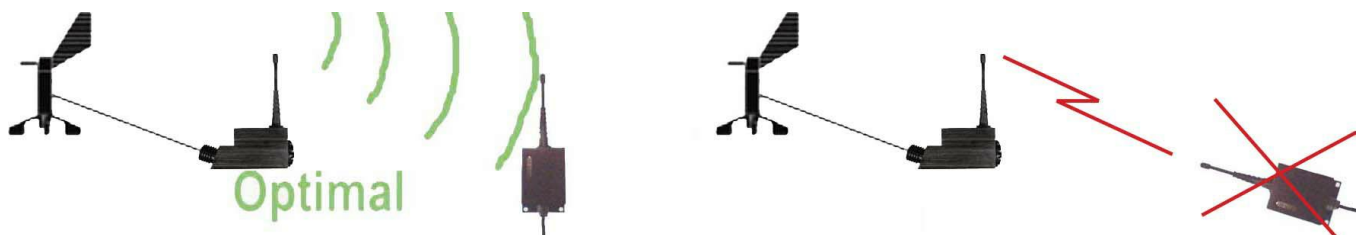

### 6.2 Receiver

- boardnet switch off (ST60-Wind display has to be without power)
- connect the cable of with the ST60-Wind display. !Watch the colors. Minus=GRAY Plus=RED.....
- switch on the boardnet
- if there is no reception of data, the hand of the display 'waves' between -30°...+30°
- place the receiver provisionally at the desired place (screw only after successful test)

### 6.3 Transmitter

- screw the ST60-Windsensor to the transmitter
- screw in the Battery
- wind direction and speed will be displayed after 5..10 seconds
- distance between transmitter <=> receiver: about length of mast
- test radio connection. see 6.4
- after successful test, install the transmitter on the mast. (2 'Imbus' screws M5, distance 30mm)  
Test of the radio connection
- control the LED's at the receiver, to see if the communication is correct. see chapter 4

## **7 Calibration**

### **7.1 ST60-Wireless**

ST60-Wireless doesn't need any calibration between transmitter and receiver.

### **7.2 Raytheon calibration**

Calibration of the total system has to take place as with the system connected through cable.

Please see original installation manual from Raytheon.

### **7.3 ST60- transmitter and/or receiver exchange**

In the case of exchange ST60-Wireless components, transmitter / receiver or both, a new calibration can be omitted (the devices don't store any calibration values) but we recommend to do it, so you will reach the best possible accuracy of the total system.

## 8 Function diagram

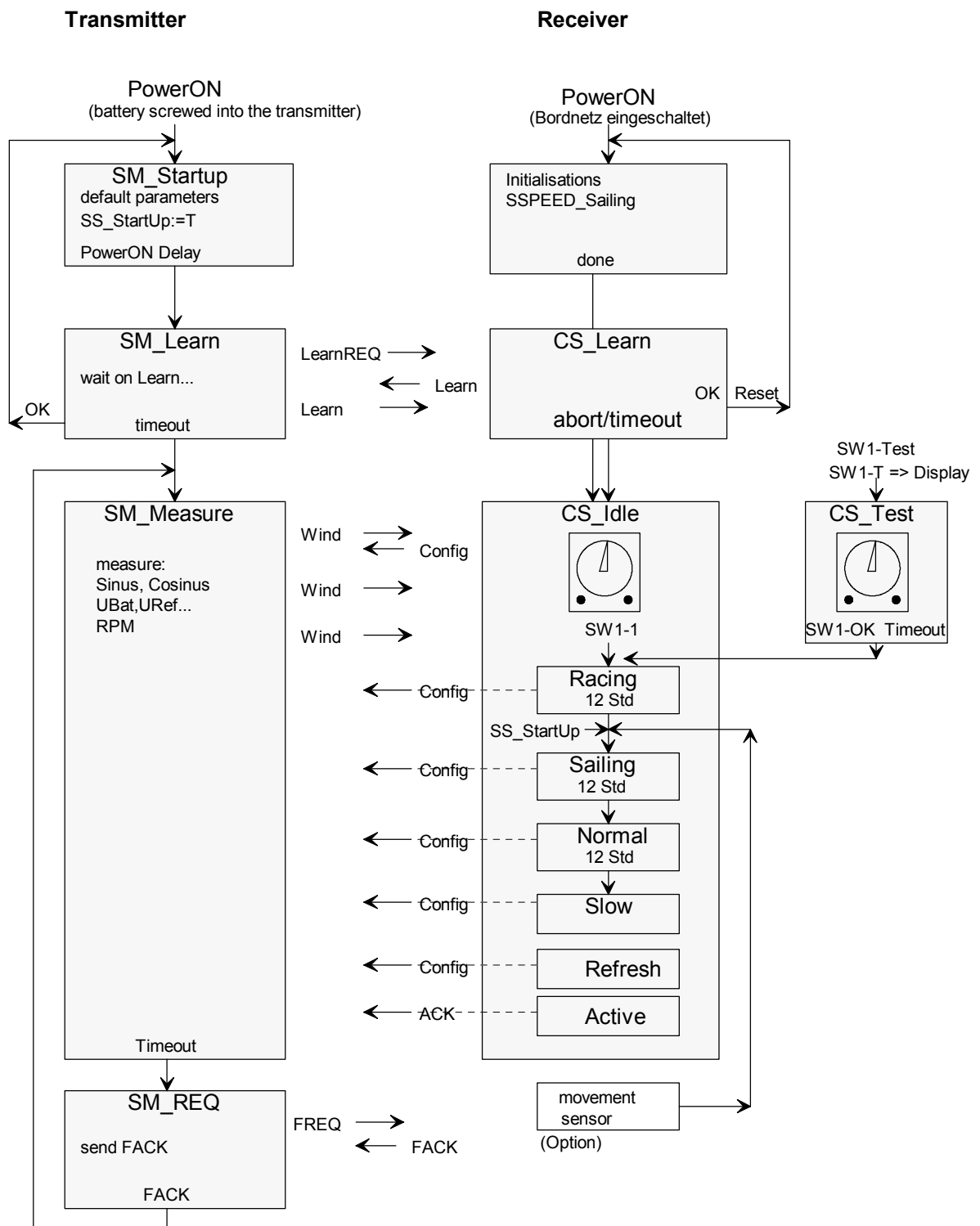

## 9 Troubleshooting

First questions ??

- is the receiver properly connected to the ST60-Wind display (check colors) ?
- are all devices switched on and is electrical power provided ?
- in what area error could be ?

windsensor => transmitter <=> radio connection => receiver => display



receiver => display

- the test mode (see chapter 4.2) gives you an easy indication, if receiver and display are properly functioning together.

radion connection => receiver

- no reception: the hand of display is "waving"
- poor reception: watch LED's: RxD, RxErr und Data

transmitter <=> receiver

- in case of a device change, have you run the 'learning mode' ?

windsensor => transmitter

The transmitter does not dispose of any display. (for a most rugged design)

But the following errors are displayed on the ST60-Wind display with '- - -':

- sensor is not screwed on the receiver
- sensor may be damaged
- measurement electronic of the transmitter may be damaged

for more 'tips and tricks', visit our homepage: [www.seawave.ch](http://www.seawave.ch)

We will publish further information....

Serial number

**Serial Nbr: 1.1.1001**

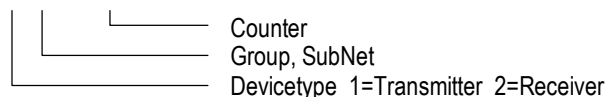

Please keep the serialnumber of your transmitter and receiver.  
It states, which exact type of device is concerned.

## 10 Dimensions

### 10.1 Transmitter

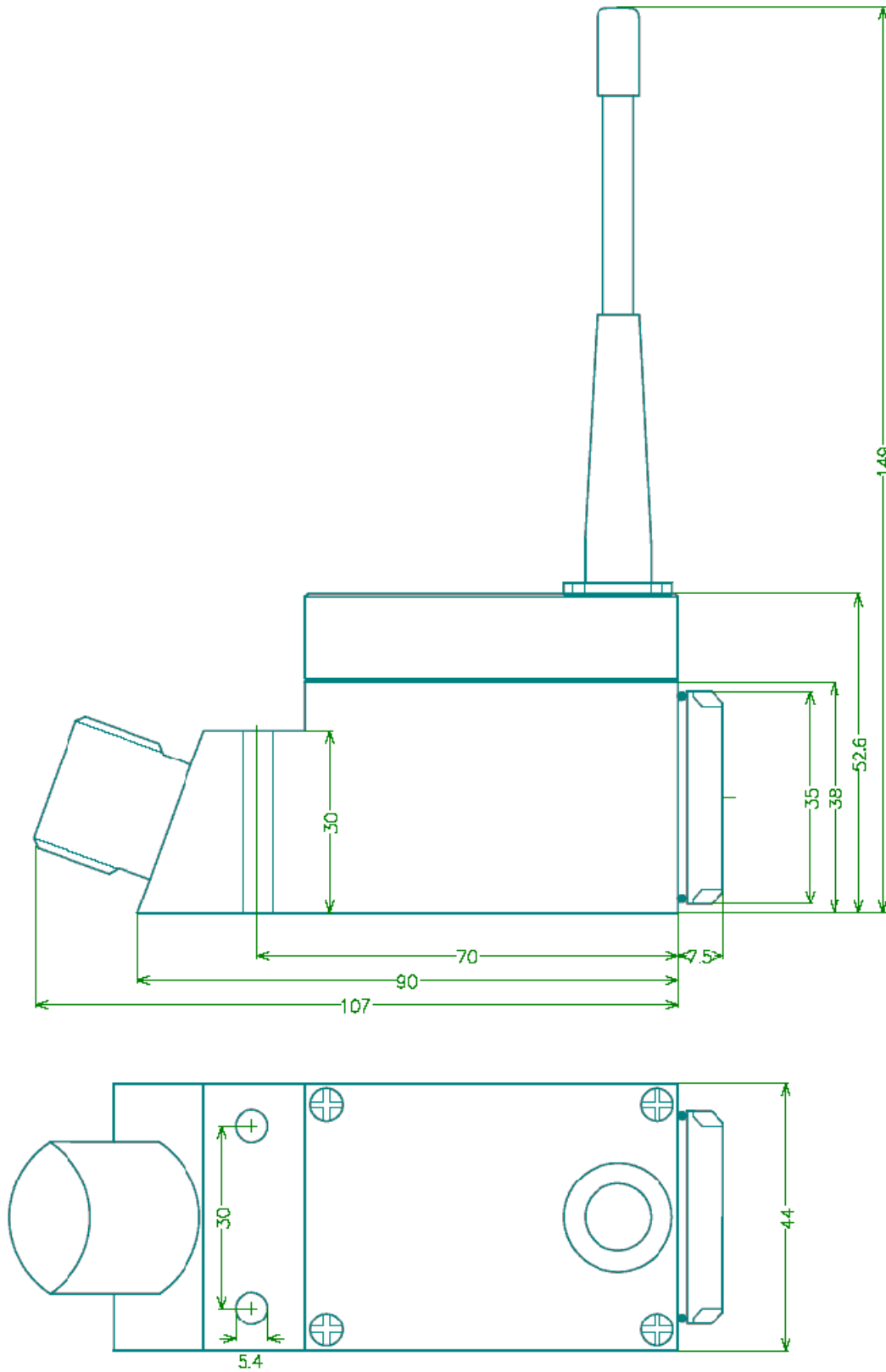

**10.2 Receiver**

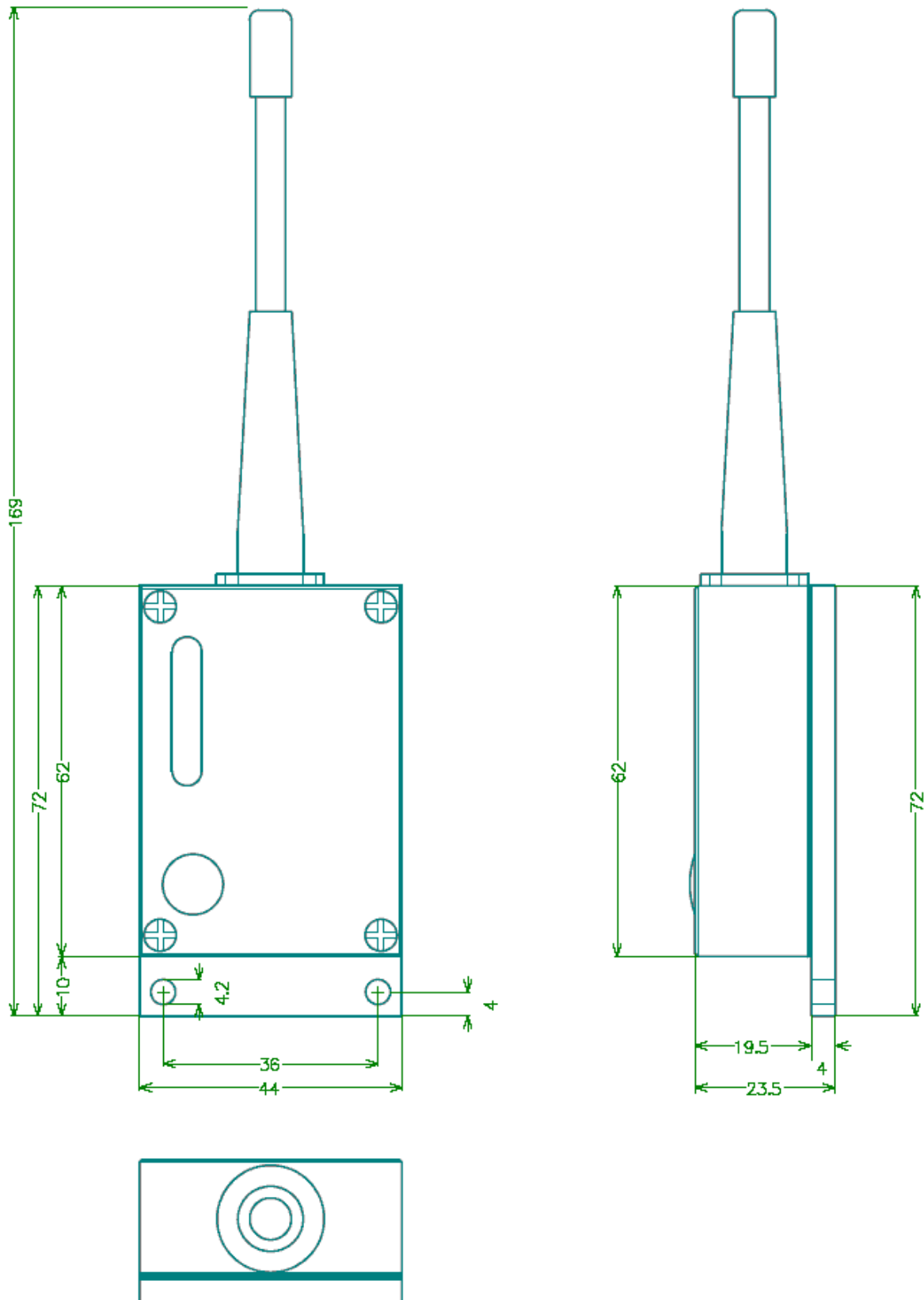

## 11 Declaration of conformity

### **DECLARATION OF CONFORMITY**

#### *KONFORMITÄTSERKLÄRUNG*

**Equipment** : Short Range Transmitter / Receiver  
*Geräteart*

**Brand** : SEAWAVE  
*Handelsmarke*

**Type** : ST60-Wireless  
*Typ* Transmitter / Receiver

**Further Description** : See technical data sheet  
*Weitere Angaben* : *Siehe Technisches Datenblatt*

The signing legal authorities state, that the above mentioned equipment meets the requirements for radio equipment and telecommunications terminal equipment and the mutual recognition of their conformity according to

- DIRECTIVE OF THE COUNCIL 1999/5/EC of 9. March 1999

*Die Unterzeichnenden erklären als rechtsverbindliche Bevollmächtigte, dass das oben erwähnte Gerät den Anforderungen über Funkanlagen und Telekommunikationseinrichtungen und die gegenseitige Anerkennung ihrer Konformität entspricht, gemäss*

- RICHTLINIE 1999/5/EG DES RATES vom 9. März 1999

The following harmonized standards have been used:

*Folgende harmonisierte Normen wurden angewandt:*

ETSI EN 300 220-3 V1.1.1 : 2000  
ETSI EN 300 220-1 V1.2.1 : 1997  
ETS 300683: 1997

**Test reports | Prüfberichte:** EMCKP134 | EMCKP134.1

**Test Laboratory :** EMC-Testcenter Zurich AG, Postfach 268, CH-8052 Zurich  
accredited according to ISO / IEC 17025

*Prüfstelle :* EMC-Testcenter Zurich AG, Postfach 268, CH-8052 Zürich  
akkreditiert gemäss ISO / IEC 17025

**Manufacturer**  
*Hersteller* Brotz Ing. Büro  
Kleindorfstr. 62  
CH-7807 Uetikon

Uetikon, 28. 04. 2003

City Date  
*Ort Datum*



Signature  
*Unterschrift*



